



THIS IS CONFIDENTIAL INFORMATION.
THIS DRAWING AND DESIGN IS THE PROPERTY OF LIQUIP INTERNATIONAL PTY LIMITED.
IT MUST NOT BE COPIED OR REPRODUCED IN ANY WAY WHATSOEVER AND/OR PASSED ON
TO ANY THIRD PARTY WITHOUT WRITTEN AUTHORITY.

LIQUIP INTERNATIONAL PTY LIMITED - ENGINEERING DEPARTMENT - 13 HUME RD SMITHFIELD SYDNEY NSW AUSTRALIA 2164
PH: +61 2 9725 9000 FAX: +61 2 9609 4739 EMAIL: engineering@liquip-nsw.com.au

LIQUIP INTERMEDIATE SWIVEL FOR LOADING ARM, 100MM (4")

DATA SHEET

PART No: VNI-A4

- TITLE:** 180° swivel for use on outboard end of loading arm, located at the top of the drop hose/spool.
- OPERATION:** A single-plane swivel mounted so that the loading coupler swings in & out relative to the tanker API adaptor.
- FEATURES:** The swivel bolts on the outboard end of the horizontal spool, above the drop hose/spool, to provide a swing action to enhance the movement of the loading coupler to better than that of hose deflection only.
- DISMANTLE:** Remove retainer plug and rotate the swivel with the hole pointing downwards until all ball-bearings have dropped out. The male of the swivel can then be removed complete with the needle bearings and seals.
- ADJUSTMENT:** None.
Grease at three-monthly intervals with recommended grease.
See Installation and Maintenance Manual for full details.
- MOUNTING:** Flanges are 100mm (4") TTMA pattern.
- TECHNICAL DATA:**
- All aluminium construction (heat treated).
 - Ball and needle rolling elements for optimum axial and radial load bearing with minimum friction.
 - Grease nipple one side with relief valve mounted opposite for efficient removal of old grease and debris.
 - Dual o-rings for product seal and dust seal respectively.
 - Viton B70 grade o-rings (* Teflon or other special seals available on request).
 - Brass ball retainer.
 - Working pressure: 1,000 kPa (145 PSI)
 - Test pressure: 1,500 kPa (218 PSI).
 - Weight: 5.6 kg (12.3lb)
 - Operating temperature: -20° to +80°C (-4° to +176°F) for EPDM & Viton B70 grade
-40° to +60°C (-40° to +140°F) for Viton GFLT grade

*** Note:**

The nature of Teflon is that it is unyielding but easily scratched; therefore the slightest damage can lead to weeps particularly where clamping force is provided by a spring which is necessarily limited in force.
However the use of Teflon cannot be avoided because of its outstanding chemical resistance.
Liquip guarantee the sealing of all new products and test all production prior to dispatch.
Following installation of the equipment by the Purchaser it is essential that the valve be kept perfectly clean, any test liquids be perfectly clean and no tools be allowed to touch the Teflon seals. It is not uncommon for valves to exhibit small weeps once in service with commercial-quality liquids.

ASSOCIATED EQUIPMENT: See Velvet Touch loading arm systems.

Overall dimensions shown on the drawing overleaf.



THIS IS CONFIDENTIAL INFORMATION.
 THIS DRAWING AND DESIGN IS THE PROPERTY OF LIQUIP INTERNATIONAL PTY LIMITED.
 IT MUST NOT BE COPIED OR REPRODUCED IN ANY WAY WHATSOEVER AND/OR PASSED ON
 TO ANY THIRD PARTY WITHOUT WRITTEN AUTHORITY.

LIQUIP INTERNATIONAL PTY LIMITED - ENGINEERING DEPARTMENT - 13 HUME RD SMITHFIELD SYDNEY NSW AUSTRALIA 2164
 PH: +61 2 9725 9000 FAX: +61 2 9609 4739 EMAIL: engineering@liquip-nsw.com.au

LIQUIP

VNI-A4 INTERMEDIATE SWIVEL

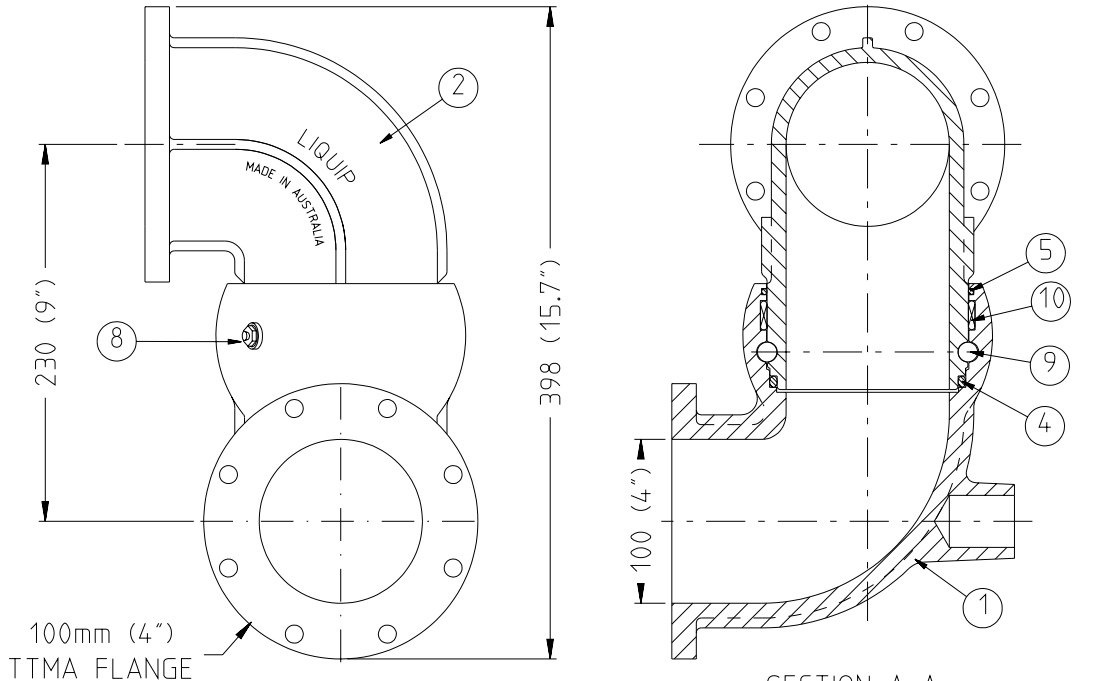

NOTES:
 1- STANDARD PRODUCT SEAL IS 0126 VITON B70 O-RING.
 IF REQUIRED IT MAY BE REPLACED WITH
 0126VG VITON GFLT O-RING OR
 4641 SPRING LOADED TEFLON SEAL.

SEE *
 NOTE 1

ITEM	PART NO	DESCRIPTION	QTY	MATERIAL
1	LAN400-6	ELBOW FEMALE 90° TO TTMA	1	ALUMINIUM
2	LAN400-7	ELBOW MALE 90° TO TTMA	1	ALUMINIUM
3	LAN400-9	PLUG RETAINER BALL BEARING	1	BRASS
4	0126	O-RING	1	VITON B70
	0126VG	O-RING	-	VITON GFLT
	4641	SEAL SPRING LOADED TEFLON	-	TEFLON
5	6080	O-RING	1	VITON B70
6	0481	NIPPLE GREASE STRAIGHT	1	Z/P M/S
7	0885	WASHER FIBRE	1	FIBRE
8	1525	NIPPLE GREASE RELEASE	1	Z/P M/S
9	2334	BALL BEARING	32	STEEL
10	4531	NEEDLE ROLLER	100	STEEL

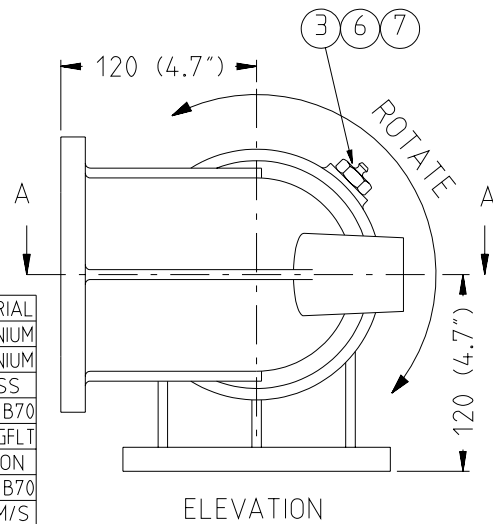

ELEVATION

X12500

Issue: H

METERS - VALVES - VENTS - MANHOLES - PUMPS - HOSEREELS - OVERFILL PROTECTION - LOADING ARMS - ELECTRONIC DIPSTICKS



LIQUIP INTERNATIONAL PTY LTD

13 Hume Road
 Smithfield, Sydney
 NSW Australia 2164
 Phone: +61 2 9725 9000
 Fax: +61 2 9725 1252

DISTRIBUTORS

See inside front cover
 for Liquip branches
 and Distributors or visit

www.liquip.com